

VR46../VR86..E, EA, EB, T, TA AND TB

COMPACT COMBINATION GAS CONTROLS WITH THROTTLE VALVE

INSTRUCTION SHEET

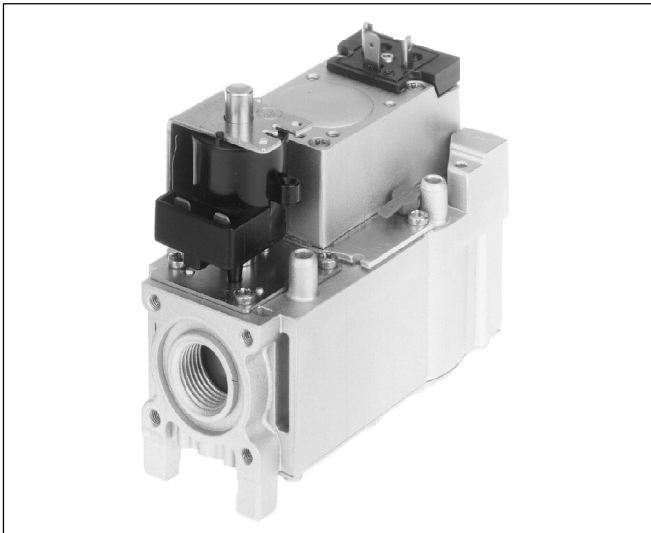

SPECIFICATIONS

Models

VR46.. series: 220/240 V, 50 Hz.

VR86.. series: 24 V, 50 Hz.

VR4601/VR8601 series:

two automatic shut off valves with pilot gas connection between the valves for intermittent pilot (IP) applications.

VR4605/VR8605 series:

two automatic shut off valves for direct spark ignition (DSI) or hot surface ignition (HSI) applications.

Suffix E: fast opening, throttle valve, medium capacity

Suffix T: softlite, throttle valve, medium capacity

Suffix EA,TA: as suffix E/T except low capacity

Suffix EB,TB: as suffix E/T except high capacity

Dimensions

See fig. 1.

Ambient temperature

0 ... 70 °C for suffix E, T, EA, TA

0 ... 60 °C for suffix EB, TB,

Pipe connection

Pipe connections are designed to meet the bending stress of group 2 according EN 161.

Standard: Inlet: 1/2" ISO 7-1 internal parallel pipe thread.

Outlet: Ø 18.6 mm without thread.

Inlet and outlet: Ø 23 mm

Inlet and outlet can also be made with straight or elbow flanges.

Special connection (optional): side outlet Ø 14 mm

Pilot gas connection (where applicable)

4 mm or 6 mm outer diameter tubing.

Special connection (optional): including in the side outlet.

Minimum differential pressure

Between inlet and outlet: 2.5 mbar

Minimum adjustable capacity

0.6 m³/h air at ΔP of 20 mbar

Maximum operating pressure

The P_{max} indication on the housing is the maximum inlet pressure at which the combination gas control functions safely.

Enclosure

IP 40 when used with V404A operator with cover and with connector mounted on first operator.

IP 44 when used with V404A operator with DIN plug according to DIN 43650 and with connector mounted on first operator.

APPLICATION

VR46../VR86..E, EA, EB, T, TA, and TB combination gas controls have been specially developed for application in domestic and small commercial atmospheric appliances with automatic ignition.

VR46../VR86..E, EA, EB, T, TA, and TB combination gas controls are used in a system context in conjunction with either a direct spark ignition (DSI) or intermittent pilot (IP) control module and associated devices to provide programmed safe light-up and supervision of the main burner of an appliance.

VR46../VR86..E, EA, EB, T, TA, and TB combination gas controls are intended to be used for manufactured, natural and LP gases (1st, 2nd, 3rd family gas).

VR46../VR86..E, EA, EB, T, TA, and TB combination gas controls are approved in accordance with existing european standards.

DESCRIPTION

VR46../VR86..E, EA, EB, T, TA, and TB combination gas controls comprise of two electrically operated shut off valves in series, a throttle valve and a slow opening mechanism (T, TA and TB models only).

The first valve is an automatic shut off valve of class B according to EN 161.

The second valve is an automatic shut off valve of class J according to EN 161.

Capacity

In m³/h air at ΔP (mbar) as shown below and electric operators horizontal.

Capacity curves are available on request.

Suffix	ΔP	Size	Flow
E, T	2.5	1/2" x Ø 18.6 mm	3.1
EA, TA	2.5	1/2" x Ø 18.6 mm	1.95
		1/2" x Ø 14 mm side outlet	1.8
TA	3	1/2" x Ø 18.6 mm	2.7
EB, TB	3	Ø 23 x Ø 23 mm	4.2

Timing (with operators vertical)

Closing time: 2 s

Dead time:

- fast open versions 1 s max.
- softlite versions see table 1.

Opening time:

- fast open versions 1 s from start of flow till 50% of outlet pressure setting.
- softlite versions 1.5 s from start of flow till softlite pressure setting.

Electrical data

Nominal voltage	Power consumption at nominal voltage (W)				Current at nominal voltage (mA)			
	1 st operator high capacity	1 st operator medium capacity	1 st operator low capacity	2 nd operator	1 st operator high capacity	1 st operator medium capacity	1 st operator low capacity	2 nd operator
24 V, 50 Hz	10	7	3.5	3.8	700	450	280	211
220/240 V, 50 Hz	-	6.5/8	3.6/4.7	3.4/4.5	-	50/60	32/36	20.4/24
220 V, 50 Hz	9.1	9.1	3.4	3.4	70	70	-	20.4
220 V, 60 Hz	-	8.3	4.9	3.5	-	57	45	21.1
230 V, 50 Hz	-	-	4.8	3.5	-	-	42	21.1
240 V, 50 Hz	8	-	3.7	4.5	60	-	-	24

INSTALLATION

IMPORTANT

Take care that installer is a trained experienced service person.

Turn off gas supply before starting installation.

Disconnect power supply to prevent electrical shock and/or equipment damage.

Do not remove seals over inlet and outlet until the device is ready to be installed.

Mounting position

The combination gas control can be mounted 0 to 90 degrees in any direction from the upright position, i.e. from the position when electric operators are on top.

Main gas connection

- Take care that dirt cannot enter the combination gas control during handling.
- Use a clean taper fitting with thread according to ISO 7-1 or a piece of new, properly reamed pipe, free from swarf.

Table 1.

Gas	Inlet pressure (mbar)	Dead time (s)
G 20/G 25	20	1.2 max.
G 30/G 31	37	1.5 max.
G 30/G 31	50	1.2 max.

Mounting holes

Two M5 mounting holes are located on the bottom of the combination gas control.

The four holes at inlet and outlet side for mounting the flange to the combination gas control are provided with M5 thread with minimum of 6.5 mm full thread.

Valve classification

1st valve: class B

2nd valve: class J

- Do not tighten the pipe or pipe fitting too far (see table 2.). Otherwise valve distortion and malfunction could result.

Table 2.

Pipe size	Max. length of pipe thread
1/2"	18.6 mm

- Apply a moderate amount of good quality thread compound to the pipe or fitting only, leaving the two end threads bare. PTFE tape may be used as an alternative.
- Ensure the gas flows in the same direction as the arrow on the bottom of the combination gas control.

Pilot gas connection (VR4601/VR8601 only)

- Square off the end of tubing and remove burrs.
- Slip compression fitting over tubing.
- Insert tubing into combination gas control housing until it bottoms, slide fitting into place and turn finger tight.
- Use a wrench to tighten fitting about 2 turns beyond finger tight for 6 mm tubing and about 3/4 turn beyond finger tight for 4 mm tubing to make a pressure tight joint. Do not use jointing compound.
- Connect other end of tubing to pilot burner according to the pilot burner manufacturer's instructions.

CAUTION

Do not bend tubing at combination gas control after compression fitting has been tightened, as this may result in gas leakage at the connection

**Remember that length of pilot tubing and pilot burner characteristics have influence on time to ignite pilot burner.
This can interfere with available ignition timings.**

Electrical connection

CAUTION

Switch off power supply before making electrical connections.

Take care that wiring is in accordance with local regulations.

To ensure a safe closing of the valve, it is essential that the voltage is reduced to 0 Volt.

Ensure that cut off function of limit control de-energizes both valves.

Use lead wire which can withstand 105 °C ambient.

The electric on/off operator is provided with 6.3 mm quick connect terminals suitable for 6.3 mm receptacles. (e.g. "Series 250" AMP fasteners)

The electric on/off servo operator is provided with quick connect terminals suitable for 6.3 mm receptacles. (e.g. "Series 250" AMP fasteners) or for a female connector according DIN 43650.

Wiring combination gas control controls in intermittent pilot (IP) systems (see fig. 2. and 4.)

The appliance manufacturer's instructions should always be followed when provided. If not available see fig. 2. for typical systems using Honeywell S458 ignition control.

Wiring combination gas control controls in direct spark ignition (DSI) systems (see fig. 3. and 5.)

The appliance manufacturer's instructions should always be followed when provided. If not available see fig. 3. for typical systems using Honeywell S4560 automatic ignition control.

WARNING

Tightness test after installation

Paint all pipe connections and gaskets with a strong soap and water solution.

Start the appliance and check for bubbles. If a leak is found in a pipe connection, remake the joint. A gasket leak can usually be stopped by tightening the mounting screws. Otherwise, replace the gasket.

Be careful not to clog bleed vent parts with soap solution residue. Remember bleed vents will discharge air during gas valve opening or closing giving false indication of leakage.

ADJUSTMENTS AND CHECKOUT

WARNING

Adjustments must be made by qualified persons only. If the appliance manufacturer supplies checkout and/or service and maintenance instructions carefully follow them. If these instructions are not provided then use the procedure outlined below.

Pressure tap

The combination gas control is provided with a pressure tap of 9 mm outer diameter at inlet and outlet side.

When checking the pressure undo the screw a half turn and slip tube over nipple.

Ensure that screw is retightened after making test.

Pilot flame (VR4601/VR8601 only)

WARNING

It should be noted, that after a long time of stoppage (summer) it can take up to 60 s to come to an ignition of the pilot burner.

Outlet pressure adjustment (see fig. 1.)

- Energize electric operators in order to have gas input to burner.
- Check input to the appliance using a clocking gas meter or alternatively a pressure gauge connected to the outlet pressure tap.
- Open cap to expose flow adjustment screw.
- Turn the flow adjustment screw with a screw driver **in either direction** until the burner pressure required is recorded on the pressure gauge.
- Close cap.

Check of slow opening (softlite)

The softlite pressure is factory set.

Check burner performance at this pressure observing burner ignition and flame characteristics. Burner should ignite promptly and without flash back to orifice and all ports should remain lit.

Cycle burner several times (wait 10 seconds between cycles to allow servo system to resume slow open action).

Repeat check of slow opening after allowing the appliance to cool down.

Checkout

Set appliance in operation after any adjustment and observe several complete cycles to ensure that all burner components function correctly.

Maintenance and service

Under normal circumstances no maintenance or service is required. Screws on the combination gas control that have been sealed must never be removed.

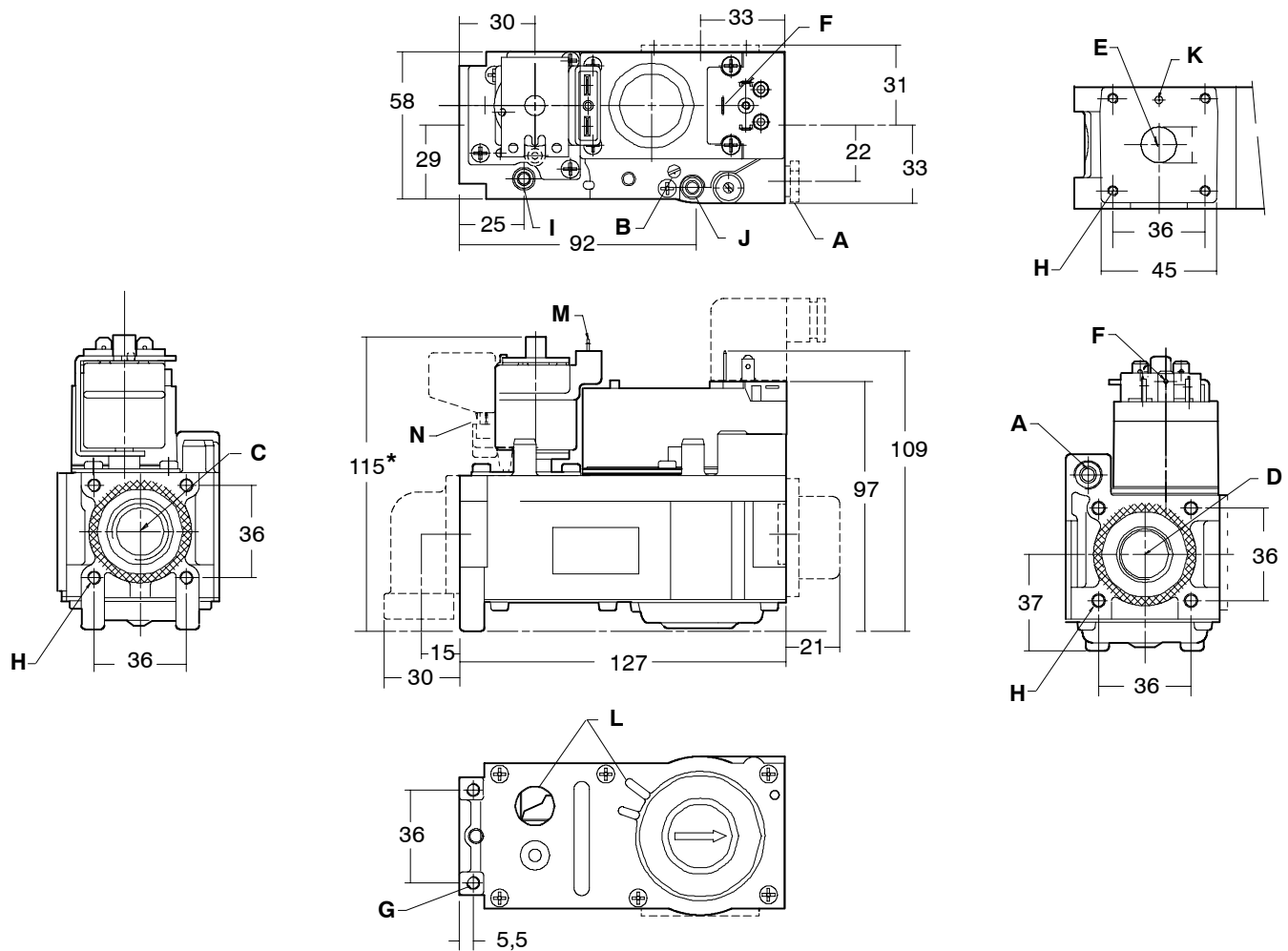

- A - Pilot outlet (if applicable)
- B - Throttle adjustment screw
- C - Inlet 1/2" ISO 7-1 or Ø 23 mm
- D - End outlet Ø 18.6 mm or Ø 23 mm
- E - Side outlet Ø 14 mm (optional)
- F - Earth terminal
- G - Mounting holes
- H - Mounting holes for flange connection
- I - Inlet pressure tap
- J - Outlet pressure tap
- K - Side pilot outlet Ø 3 mm (optional)
- L - Softlite version
- M - High terminal connection
- N - Low terminal connection

Fig. 1. Dimensions and adjustment points

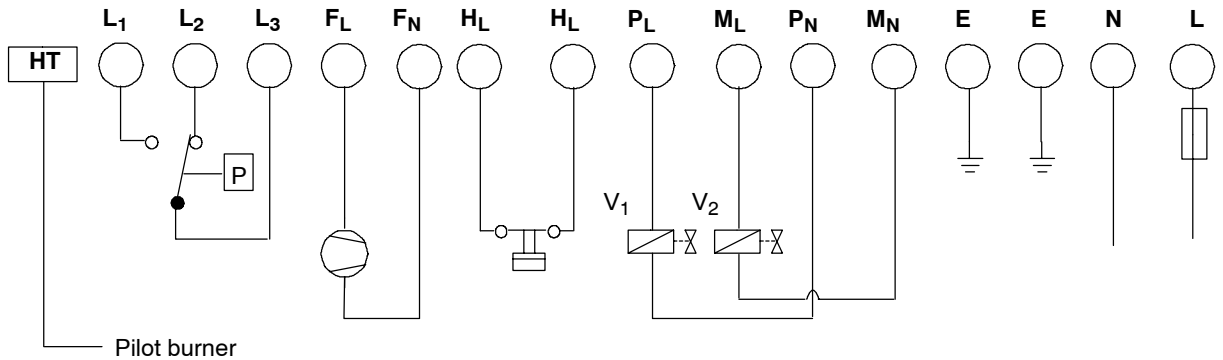

Fig. 2. Connection diagram S458 ignition control

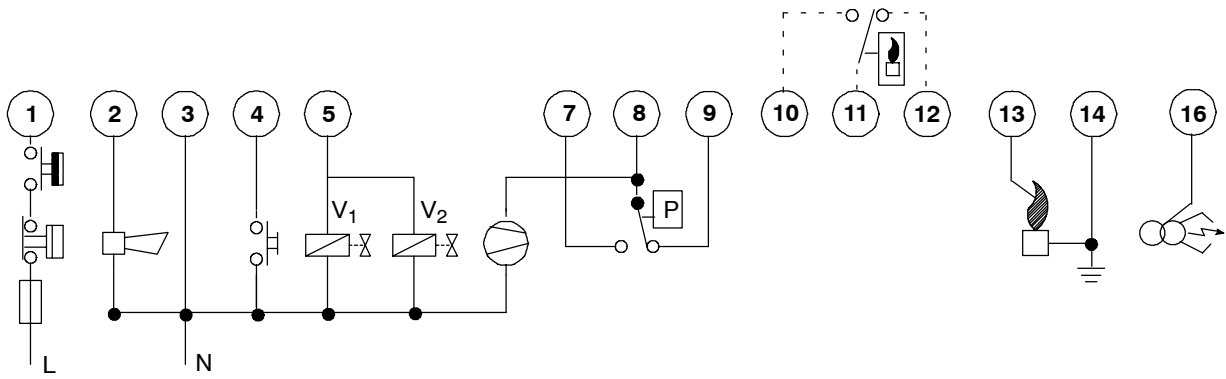

Fig. 3. Connection diagram S4560 ignition control

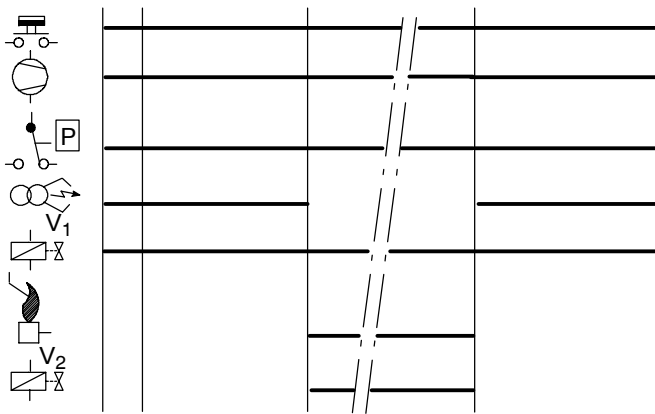

Fig. 4. Functional diagram S458

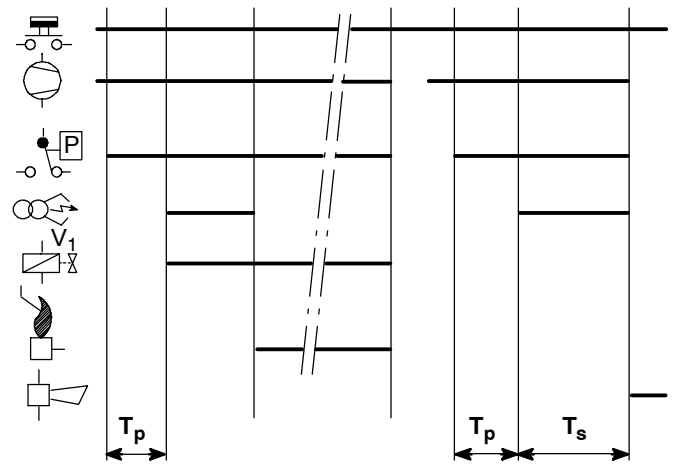

Fig. 5. Functional diagram S4560

Thermostat	Gas valve	Ignition	Flame rod	Fan	Limiter	Reset switch	Flame indication relay	Alarm	Air proving switch

Fig. 6. Legend for fig. 2., 3., 4. and 5.